

DEPARTAMENTO DE  
**SALUD**



# Deliverable 217-ICD: Labor Batch Participant Information: Interface Control Document (ICD)

MEDITI3G Project  
Government of Puerto Rico

**Version 2.1**  
**September 16, 2022**  
Contract #2022-DS0707

## Document Revision History

*Table 1 - Document Revision History*

Version Number	Date	Description
<b>1.0</b>	6/18/2021	Submission of the document for approval.
<b>2.0</b>	3/31/2022	<p>The following changes were made to the document:</p> <ul style="list-style-type: none"> <li>Updated Logo, Deliverable Title, Contract number, document version number to 2.0, and re-submission date.</li> <li>Update Header logo and Deliverable Title</li> <li>Update Footer Date and Version Number</li> <li>Changed throughout the document the use of "will", "should", "would", and "could" to "shall".</li> </ul> <p>Updated Table 2: Document Approval (page iv) and Table 3: Team members (page 3), based on changes of personnel within the team and stakeholders.</p> <p style="padding-left: 40px;">Page iv: Updated the Table of Contents to reflect the addition of the aforementioned tables.</p> <p>Updated Section 1</p> <ul style="list-style-type: none"> <li>Updated Section 1.1</li> <li>Updated Section 1.2</li> <li>Updated Section 1.3</li> <li>Updated Section 1.4</li> </ul> <p>Updated Section 2</p> <ul style="list-style-type: none"> <li>Updated Section 3.1</li> <li>Updated Section 3.2</li> <li>Updated Section 3.3</li> <li>Updated Section 4</li> <li>Updated Section 4.1</li> <li>Updated Section 4.2</li> <li>Updated Section 4.3</li> <li>Updated Section 4.4</li> <li>Updated Section 4.5</li> <li>Updated Section 5.1.1</li> <li>Updated Section 5.1.2</li> <li>Updated Section 5.1.3</li> <li>Updated Section 5.1.4</li> <li>Updated Section 5.1.5.2</li> <li>Updated Section 5.1.5.3</li> <li>Updated Section 5.1.5.3.1.1</li> <li>Updated Section 5.1.5.3.1.2</li> </ul>

Version Number	Date	Description
		Updated Section 5.1.5.3.1.3
		Updated Section 5.1.5.3.1.4
		Updated Section 5.2.5.3.2.1
		Updated Section 5.1.5.3.2.2
		Updated Section 5.1.5.3.2.3
		Updated Section 5.1.5.3.3.1
		Updated Section 5.1.5.3.3.2
		Updated Section 5.1.5.3.3.3
		Updated Section 5.1.6
		Updated Section 5.1.6.2
		Updated Section 5.1.7
		Updated Section 6.1
		Updated Section 6.2
		Updated Section 7
		Updated Section 8
		Updated Section 9
		Updated Section 11 Appendix A
		Updated Section 12 Appendix B
		Updated Section 13 Appendix C
		Updated Section 14 Appendix D
		Updated Section 15 Appendix E
		Updated Section 16 Appendix F
		Updated Section 17 Appendix G
		Updated Section 18 Appendix H
		Updated Section 19 Appendix I
		Updated Section 20 Appendix J
		Updated Section 21 Appendix K



## Document Approval

*Table 2 - Document Approval*

Stakeholder Name	Stakeholder Role	Stakeholder Signature	Signature Date (MM/DD/YYYY)
<b>Alexander Quevedo</b>	State HIT Coordinator		

**Send inquiries to:**  
**Wovenware**  
**1000 Calle Los Angeles Suite 100**  
**San Juan, PR 00909**  
**E-Mail:**  
[\*\*mediti3g@wovenware.com\*\*](mailto:mediti3g@wovenware.com)

## Table of Contents

<b>DOCUMENT REVISION HISTORY</b>	<b>II</b>
<b>TABLE OF CONTENTS</b>	<b>V</b>
<b>1. INTRODUCTION</b>	<b>9</b>
1.1. Purpose of Interface Control	9
1.2. Scope	9
1.3. Team Members	10
1.4. Glossary of Terms	11
<b>2. OVERVIEW</b>	<b>14</b>
<b>3. ASSUMPTIONS/CONSTRAINTS/RISKS</b>	<b>14</b>
3.1. Assumptions	14
3.2. Constraints	15
3.3. Risks and Issues	15
<b>4. GENERAL INTERFACE REQUIREMENTS</b>	<b>16</b>
4.1. Interface Overview	16
4.2. Functional Allocation	17
4.3. Data Transfer	18
4.4. Transactions	23
4.5. Security and Integrity	24
<b>5. DETAILED INTERFACE REQUIREMENTS</b>	<b>24</b>
5.1. Requirements for Labor Batch Participant Information Interface	24
5.1.1. Assumptions	25
5.1.2. Constraints	25
5.1.3. General Processing Steps	25
5.1.4. Interface Processing Time Requirements	29
5.1.5. Message Format (or Record Layout) and Required Protocols	30
5.1.5.1. File Layout	30
5.1.5.2. Data Assembly Characteristics	30
5.1.5.3. Field/Element Definition	31
5.1.6. Communication Methods	41
5.1.6.1. Interface Initiation	42
5.1.6.2. Flow Control	42
5.1.7. Security Requirements	44
<b>6. XML SCHEMAS</b>	<b>45</b>
6.1. Request and Response Manifest Schemas	45
6.2. Labor Request and Response Schemas	45
<b>7. QUALIFICATION METHODS</b>	<b>47</b>



---

<b>8. RELATED DOCUMENTS</b>	<b>47</b>
<b>9. REQUIREMENTS MATRIX</b>	<b>49</b>
<b>10. ISSUE REGISTER</b>	<b>57</b>
<b>11. APPENDIX A – LABOR CONNECTIVITY AND MAINTENANCE PLAN</b>	<b>58</b>
<b>12. APPENDIX B – LABOR BATCH DATA LAYOUT</b>	<b>58</b>
<b>13. APPENDIX C - LOCATIONSTATEUSPOSTALSERVICECODE ACCEPTED VALUES</b>	<b>59</b>
<b>14. APPENDIX D - PRLABORPERSONADDRESSCATEGORYCODE ACCEPTED VALUES</b>	<b>63</b>
<b>15. APPENDIX E - PRLABORPERSONBENEFITTYPE ACCEPTED VALUES</b>	<b>63</b>
<b>16. APPENDIX F - PRLABORPERSONBENEFITDELIVERYTYPE ACCEPTED VALUES</b>	<b>64</b>
<b>17. APPENDIX G - PRLABORBENEFITENDREASON ACCEPTED VALUES</b>	<b>65</b>
<b>18. APPENDIX H – PRLABORPERSONBENEFITSTATUSCODE ACCEPTED VALUES</b>	<b>65</b>
<b>19. APPENDIX I – PRLABORPERSONBENEFITSEPARATIONREASONCODE VALUES</b>	<b>66</b>
<b>21. APPENDIX K – DEFAULT VALUES MAPPING</b>	<b>68</b>

## **LIST OF TABLES**

Table 1 - Document Revision History	ii
Table 2 - Document Approval	iv
Table 3 - Team Members	10
Table 4 - Glossary of Terms	11
Table 5 - File Naming Convention for the State Hub ZIP Files	19
Table 6 - Description of the File Naming Standards for the State Hub SFTP File Naming Conventions	19
Table 7 - Labor Batch Participant Information Interface Processing Steps	26
Table 8 - Labor Batch Participant Information Interface Response Processing Steps	27
Table 9 - Labor Batch Participant Information Interface Response Processing Steps When the Maximum Response Time has Reached	28
Table 10 - Labor Batch Participant Information Interface Processing Steps to Delete Inbound File That is 14 Days or Older	28
Table 11 - Labor Batch Participant Information Interface Processing Steps to Delete Outbound File That is 14 Days or Older	29



Table 12 - Results in cases where the maximum response time is exceeded	29
Table 13 - Request Manifest Schema: Requester to State Hub Inbound Batch File	32
Table 144 - NACK Manifest Schema: State Hub to Requester NACK file	33
Table 155 - NACK Manifest Schema: State Hub to Requester NACK Manifest ResponseCodes	34
Table 16 - NACK Manifest Schema: State Hub to Requester NACK Manifest Category Codes	34
Table 17 - Response Manifest Schema: State Hub to Requester File Response	35
Table 18 - Response Manifest Schema: State Hub to Requester ResponseCodes	37
Table 19 - Response Manifest Schema: State Hub to Requester BatchCategoryCodes	37
Table 20 - Request Data Elements: Labor Batch Participant Information Interface to Labor Batch System File Request	39
Table 21 - Response Data Elements: Labor Batch Interface to Requestor System File Response	40
Table 22 - ResponseCode: Labor Batch Interface LocalAgencyBatchResponseCode41	
Table 23 - ResponseCode: Labor Batch Interface LocalAgencyIndividualResponse/ResponseCode	41
Table 24 - Related Documents	47
Table 25 - General Functional Requirements	49
Table 266 - General Non-Functional Requirements	54
Table 277 - Issue Register	57
Table 288 - US Postal Service Codes	59
Table 299 - PR Labor Person Address Category Codes	63
Table 30 - PR Labor Person Benefit Type Codes	63
Table 31 - Labor Benefit Frequency Codes	64
Table 32 - Labor Benefit End Reason Codes	65
Table 33 - Labor Person Benefit Status Codes	65
Table 344 - Labor Person Benefit Separation Reason Codes	66

## **LIST OF FIGURES**

Figure 1 - Labor Batch Participant Information Interface Enterprise Architecture	17
Figure 2 - Inbound Labor ZIP file with batch requests	20
Figure 3 - Outbound Labor ZIP file with responses	21
Figure 4 - Outbound Labor Zip file with NACK	22
Figure 5 - Transaction between MEDITI3G - Local Interface - Labor sequence	23
Figure 6 - High-Level Request Manifest UML	32
Figure 7 - High Level NACK Manifest UML	33
Figure 8 - High Level Response Manifest UML	35

Figure 9 - High Level Labor Request UML	38
Figure 10 - High Level Labor Response UML	40
Figure 11 - Labor Batch Participant Information Interface Process Flow	43
Figure 12 - Labor Request and Response Manifest Schema	45
Figure 13 - Labor Request and Response File Schema	46
Figure 14 - Labor Batch Data Layout	58
Figure 15 - Labor System Response Default Values Mapping	68



## 1. Introduction

The following document shall describe in detail the interaction of one of these Data Verification Interfaces hosted in the State Hub. The State Hub is the Data Hub for MEDITI3G Initiative of the Puerto Rico Department of Health. The Department of Labor Batch Participant Information Interface (henceforth Local Interface) is an interface between the MEDITI3G System and the Labor System. The MEDITI3G System shall send a batch request file to the interface to gather information about the applicant/beneficiary in Labor System. The interface shall collect the information returned by the Department of Labor (henceforth Local Agency) and return it to the MEDITI3G System. As part of the efforts to move forward with MEDITI3G, the Local Interface shall be part of the State Data Verification Hub (henceforth State Hub).

### 1.1. Purpose of Interface Control

This Interface Control Document (ICD) documents and tracks the information required to define the Local Interface, which establishes connection and interaction between the MEDITI3G System and the Labor System, aiming to bridge access to critical participant information from the Local Agency through the State Hub via batch transactions. This document establishes the specifications that the Local Interface shall contain in general, the connectivity standards between the systems, the message formatting to communicate the systems, which capabilities shall be shall by the interface, and the security considerations that shall be met.

The intended audience of the Local Interface ICD is composed of all project stakeholders, including the project sponsor, senior leadership, and the project team.

### 1.2. Scope

This document describes the service interactions, assumptions, activities, constraints, process flow, and data elements for the Local Interface. The data elements that the interface shall process from the Local Agency are resource income, the amount, and payment frequency.

The following list defines the functionalities that are within the scope of this deliverable:

- The MEDITI3G System shall submit the PRMP participant information collection of requests to be processed by the Local Interface to look up the information in the Labor System via batch transactions.
- The interface shall convert the responses to the standard format.
- Request and response schema validations shall be done by the Local Interface. All specified/provided rules are explained in detail in Section 5: [Detailed Interface Requirements](#).
- Log Local Interface audit trail.
- Errors shall be classified as system or data errors and shall be logged independently within the Local Interface for reference purposes.
  - System errors are those related (but not limited) to (1) an unexpected error while the interface processes the requested file.
  - Data errors are those that occurred while enforcing the data validation rules described in section 5: Detailed Interface Requirements.
- The Local Interface shall be MARS-E and HIPAA compliant. Security measures shall be performed to follow PRDoH security standards and procedures. To comply with security guidelines rules, all extracted data shall be handled in the State Hub internal network and shall not be transmitted outside the network while being processed. The requests and responses shall not be persisted in the State Hub, except for the files that are not processed within 14 days.

### 1.3. Team Members

The following team members shall provide their feedback for this document.

*Table 3 - Team Members*

Participants	Organization
Héctor L. Ríos Miranda	Labor
Victor Ortiz Pizarro	Labor
Christy Schilling	BerryDunn
Jean Beaty	PMO
Blake Hansard	PMO
Alexander Quevedo	PRMP
Irma Avilés	PRMP

Participants	Organization
Evelyn Santos	PRMP
Iván Imbert	PRMP
Ryon Johnson	RedMane
Stephanie Nieves	RedMane
Brandon Peclyak	RedMane
Tamera Jones	Redmane

## 1.4. Glossary of Terms

*Table 4 - Glossary of Terms*

Acronym/Term	Definition
<b>AES</b>	Advanced Encryption Standard
<b>Labor</b>	“Departamento del Trabajo” (Department of Labor)
<b>CIO</b>	Chief Information Officer
<b>CMS</b>	Centers for Medicare & Medicaid Services
<b>DOB</b>	Date of Birth
<b>EFT</b>	Electronic File Transfer
<b>FIPS</b>	Federal Information Processing Standards
<b>FPLS</b>	Federal Parent Locator Service
<b>FUNC</b>	Function
<b>GB</b>	Gigabyte
<b>GHP</b>	Government Health Plan
<b>HIPAA</b>	Health Insurance Portability and Accountability Act
<b>HIT</b>	Health Information Technology
<b>HITECH</b>	Health Information Technology for Economic and Clinical Health
<b>HTTPS</b>	Hypertext Transfer Protocol Secure
<b>ICD</b>	Interface Control Document
<b>IRS</b>	Internal Revenue Service



<b>Acronym/Term</b>	<b>Definition</b>
<b>IV&amp;V</b>	Independent Verification & Validation
<b>KB</b>	Knowledge Base (usually referred to Microsoft issued patches)
<b>MARS-E</b>	Minimum Acceptable Risk Standards for Exchanges
<b>MEDITI3G</b>	Medicaid Integrated Technology Initiative Third Generation
<b>MOU</b>	Memorandum of Understanding
<b>NACK</b>	Negative Acknowledgment (NACK) files are the way the Local Interface shall transmit to the Requestor System that an error occurred
<b>NIEM</b>	National Information Exchange Model
<b>OIAT</b>	Puerto Rico Department of Health's System Information Department. In Spanish means: "Oficina de Informática y Avances Tecnológicos"
<b>PGP</b>	Pretty Good Privacy
<b>PII</b>	Personally Identifiable Information
<b>PMO</b>	Project Management Office
<b>PRDoH</b>	Puerto Rico Department of Health
<b>MEDITI3G</b>	Medicaid Integrated Technology Initiative 3rd Generation
<b>Requestor System</b>	Name to identify the solution used by the PRMP case workers for eligibility management.
<b>PRMP</b>	Puerto Rico Medicaid Program
<b>Requester</b>	Administrator, auditor, or consumer of service providers
<b>RSA</b>	Rivest-Shamir-Adleman Cryptosystem
<b>SHA</b>	Secure Hash Algorithm
<b>SFTP</b>	Secure File Transfer Protocol
<b>SLA</b>	Service Level Agreement
<b>SI</b>	System Integrator
<b>SOAP</b>	Simple Object Access Protocol
<b>SSH</b>	Secure Shell
<b>SSN</b>	Social Security Number
<b>SSP</b>	System Security Plan
<b>TDS</b>	Trusted Data Source
<b>TLS</b>	Transport Layer Security
<b>UML</b>	Unified Modeling Language



<b>Acronym/Term</b>	<b>Definition</b>
<b>UNIX</b>	Uniplexed Information and Computer Systems
<b>VPN</b>	Virtual Private Network
<b>XML</b>	Extensible Markup Language

## 2. Overview

The Puerto Rico Department of Labor is the executive department of the government of Puerto Rico responsible for developing the interests and well-being of the workers in the U.S. Commonwealth of Puerto Rico.

The Requestor System, through these batch requests, shall query the Local Interface for information regarding a participant information in a Local Agency. The batch requests shall contain a participant's basic personal identifiable information. The Local Interface shall interact with the Local Agency to find the information in their system and return it to the Requestor System.

This solution establishes that the Local Interface is implemented as core components of the State Hub in an Azure Government environment to guarantee high availability, redundancy, data integrity, and data security using the HIPAA Privacy Rule, HIPAA Security Rule, and the Center for Medicare and Medicaid Services (CMS) Standards and Conditions as the basis.

## 3. Assumptions/Constraints/Risks

Several factors influence the expectations of the Local Interface. They have been categorized as assumptions, constraints, and risks.

### 3.1. Assumptions

The following assumptions apply to the Labor Batch Interface:

1. There shall be a signed Memorandum of Understanding (MOU) agreement in place with Labor to allow the sharing of Labor System information.
2. The Requestor System shall use the interface to determine the renewal eligibility of PRMP beneficiaries.
3. The Local Agency shall promptly notify PRDoH and Wovenware the identified MEDITI3G operational personnel of any maintenance window not previously scheduled or agreed upon.

4. The Local Agency shall have maintenance windows at least one or two times a month during the weekends.
5. Azure Government cloud shall maintain backward compatibility for up to three (3) versions allowing enough time to update code for new offerings of services and components. The inclusion of new offerings later shall not negatively impact compatibility and compliance with HIPAA and MARS-E.
6. The identified MEDITI3G key personnel shall establish the necessary procedures to grant access to the SFTP Server.

### **3.2. Constraints**

This section defines limitations, such as external dependencies, identified during the interfaces' requirements gathering.

The interface shall be dedicated to communicating to a single Trusted Data Source (TDS) for requesting data.

The State Hub, the environment that shall contain the Local Interface, shall not handle ZIP (batch) files greater than 100 Megabytes (MB). The Azure Government Cloud imposes a limit of 100 Gigabytes (GB).

The Federal Hub implements NIEM 2.0 and has not indicated when they shall upgrade. Since newer versions are not backward compatible with older versions, the State Hub and the Local Interfaces shall also use NIEM 2.0.

### **3.3. Risks and Issues**

No risks nor issues are currently open in the project's SharePoint site: [FREE DDI - Home \(sharepoint.com\)](#)

## 4. General Interface Requirements

This section describes the general functional decomposition of the Local Interface used by Requestor System when requesting an applicant's/beneficiary's information from Labor's System. In addition, it shall cover the security and integrity requirements needed for the request to be considered successful and achievable.

### 4.1. Interface Overview

The Local Interface residing in the State Hub shall connect the Requestor System with the Labor System seeking to acquire beneficiaries' personal information in an Application-to-Application asynchronous behavior.

The interface is expected to receive an encrypted batch request file(s) from the Requestor System monthly, at a minimum, through SFTP. The interface shall handle up to one (1) ZIP files for batch processing. The batch request file contains individual requests with beneficiaries' personally identifiable information that can be used to locate the beneficiary's information within the agency's system, information such as SSN, Name, and Date of Birth (DOB).

The interface shall validate the received file and place the requests for the Local Agency to retrieve from the Labor Batch Participant Information Interface via State Hub SFTP.

The Local Agency shall process and respond via SFTP to the Labor Batch Participant Information Interface with the participant's personal information, address, the income reported to the agency and benefits received by the agency. More details can be found in Section **Error! Reference source not found. - Error! Reference source not found..**

Alternatively, the Local Agency shall determine instead to return a negative acknowledgment (NACK) back to the interface in the scenarios where the Local Agency cannot process the submitted batch request file, scenarios such as when the batch request file fails validation.

Once the responses have been received from the agency, the interface shall pack the response(s) in a ZIP folder and pass it through to Requestor System via the State Hub SFTP Server.

Alternatively, the interface shall determine instead to return a negative acknowledgment (NACK) to Requestor System in the scenarios where the interface cannot process the submitted batch request file, scenarios such as when the batch request file fails validation.

Finally, Requestor System shall be able to retrieve and delete the response from the Local Interface via SFTP.



Figure 1 - Labor Batch Participant Information Interface Enterprise Architecture illustrates a high-level view of the interaction between the Requestor System, the Local Interface, and Labor.

*Figure 1 - Labor Batch Participant Information Interface Enterprise Architecture*

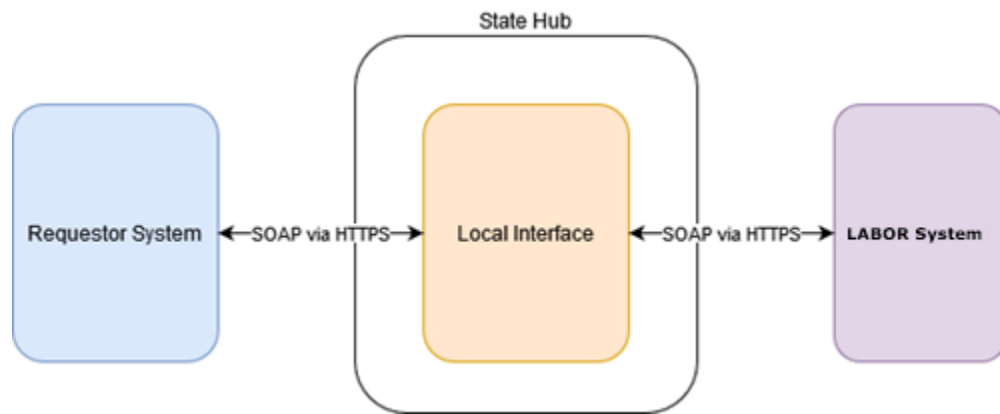

In Figure 1, the Requestor System is the entity in charge of initiating the batch request via SFTP with the Local Interface. The Labor System is the Local Agency system that the Local Interface shall interact with to request applicants/beneficiary’s information. The Local Interface is hosted in the State Hub and shall validate the Requestor System requests, send the requests to Labor via SFTP, receive Labor responses via SFTP and deliver the responses back to the Requestor System via the State Hub SFTP Server.

## 4.2. Functional Allocation

The interaction between the Requestor System and the Local Interface is triggered when the Requestor System deposits the batch request file in the inbound folder. A mechanism shall be activated when a file is deposited. As a result of this trigger, the Local Interface shall commence the business operation to process the requests against the Labor System to gather the participant information. The process is compliant with the Patient Protection and Affordable Care Act of 2010, Section 1561. The schema that the requests shall contain is detailed in section 5.1.5 Message Format (or Record Layout) and Required Protocols.

The business operation to process the requests against the Labor System to gather the participant information shall be affected if the process has reached the maximum response time. At this moment, the Local interface shall prepare and return a NACK

to the Requestor System. Afterward, the Requestor System retrieves and reads the NACK response, Requestor System shall then opt to resubmit the batch request.

The interface shall monitor the request files left in the Inbound folder and if a batch request file is left in the Inbound folder for more than fourteen (14) days then a business process shall take place to securely remove the file. The High-Level Design Document for this interface shall further describe this business process in detail.

The interface shall monitor the response files left in the Outbound folder and if a response file is left in the Outbound folder for more than fourteen (14) days then a business process shall take place to securely remove the file.

### 4.3. Data Transfer

The Requestor System requests information from the Labor System through the State Hub by placing an encrypted ZIP file containing a manifest file and the requests in XML format for the agency in the established SFTP folder. The interface shall validate the XML files against the National Information Exchange Model (NIEM) standards. Authentication and authorization details for the SFTP folder are discussed in Section 4.5 Security and Integrity.

[Table 5 - File Naming Convention for the State Hub ZIP Files](#) describe the file naming conventions, attributes of the compressed ZIP file, and the folder name where the Requestor System shall place each request file to be processed against the Labor System.

The **FUNC** attribute for the Labor Batch Interface is **LABORBPII**.

*Table 5 - File Naming Convention for the State Hub ZIP Files*

SFTP Folder	Filename
<b>Inbound folder</b> <b>For Inbound (Requester to State Hub)</b>	SOURCEID.FUNC.DATE.TIME.ENV.IN e.g., MEDITI3G.LABORBPII.D191114.T065423325.T.IN.zip
<b>Outbound (Response) Folder</b> <b>For NACK (State Hub to Requester)</b>	SOURCEID.FUNC.NAK.DATE.TIME.ENV.OUT e.g., MEDITI3G.LABORBPII.NAK.D191114.T065423325.T.OUT.zip
<b>Outbound (Response) Folder</b> <b>For Response (State Hub to Requester)</b>	SOURCEID.FUNC.DATE.TIME.ENV.OUT e.g., MEDITI3G.LABORBPII.D191114.T065423325.T.OUT.zip

Table 6 - Description of the File Naming Standards for the State Hub SFTP File Naming Conventions defines the specific information for each attribute in the Inbound and Outbound State Hub SFTP ZIP filenames.

*Table 6 - Description of the File Naming Standards for the State Hub SFTP File Naming Conventions*

Attribute	Description
<b>SourceID</b>	The source identification given to the Requestor to identify State Hub request match file.
<b>Func</b>	The specific data function that is requested to the State Hub.
<b>Date</b>	The date of the file submitted identified by the following format DYYMMDD
<b>Time</b>	The timestamp of the file submitted identified by the following format THHMMSSNNN (if milliseconds are not available, any three digits shall be used, as long as the resultant filename is unique)

Attribute	Description
<b>Env</b>	The environment in which the file is being submitted (P for Production Environment (PROD), T for non-PROD)
<b>In</b>	File extension mandated for files Inbound to Electronic File Transfer (EFT) Note: This is only applicable for the Inbound folder.
<b>Out</b>	Transfer direction Note: This is only applicable for the Outbound folder.

Section 5.1.5.3 Field/Element Definition contains a description of the schema each XML file shall contain to pass validations and be routed to the Labor System.

Figure 2 - Inbound Labor ZIP file with batch requests illustrates a batch request in the designated Local Interface Inbound folder with one manifest and one Labor batch request file. The manifest file contains metadata information about the files within the ZIP file. See section 5.1.5.3 Field/Element Definition for more details.

*Figure 2 - Inbound Labor ZIP file with batch requests*

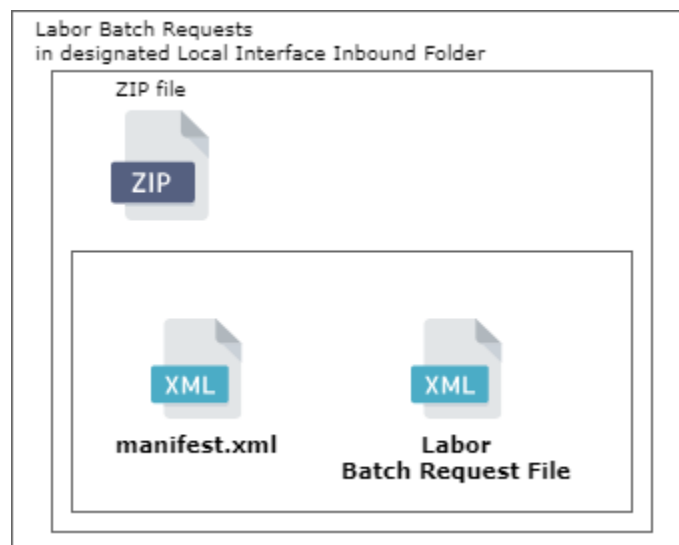

The interface shall request the information from Labor using the Labor Batch Request XML file passed via the established SFTP folder. The requests sent and the responses received from the database are processed in XML format.

After the interface has received in XML format all the responses from the Labor System, a response file and a manifest file are created in XML format following NIEM standards, the resulting files are compressed into a ZIP file and uploaded to the established SFTP folder for Requestor System to download them.

Figure 3 - Outbound Labor ZIP file with responses illustrates a batch response in the designated Local Interface Outbound folder with one manifest and one Labor batch response file.

Figure 3 - Outbound Labor ZIP file with responses

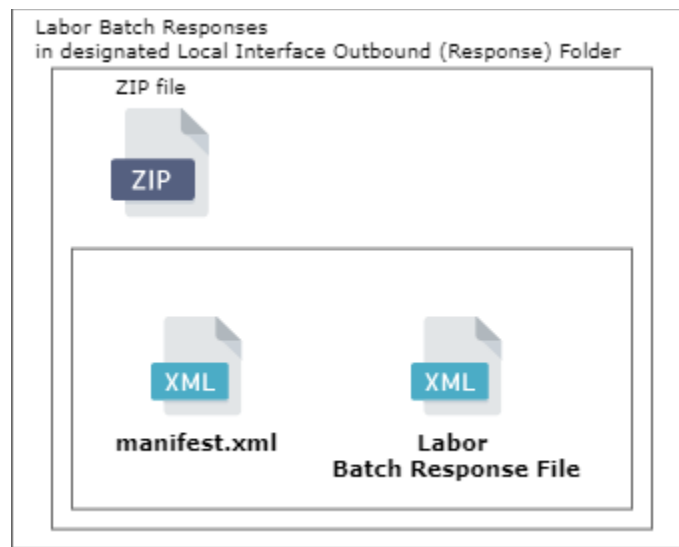

When a validation error of the whole batch request file has occurred at the TDS, the TDS shall create and return to the interface a NACK file containing information about the batch that generated the error and an error code to identify the type of error. The interface shall prepare and send a NACK file to the Requestor System.

Figure 4 - Outbound Labor Zip file with NACK illustrates a NACK in the designated Outbound folder with one manifest. A NACK only contains one manifest file within the ZIP file.

Figure 4 - Outbound Labor Zip file with NACK

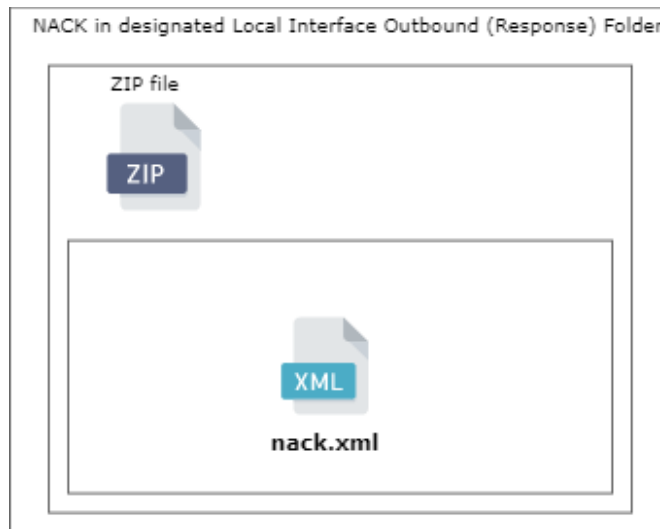

## 4.4. Transactions

The batch request file transaction between Requestor System and Labor System is described below:

*Figure 5 - Transaction between MEDITI3G - Local Interface - Labor sequence*

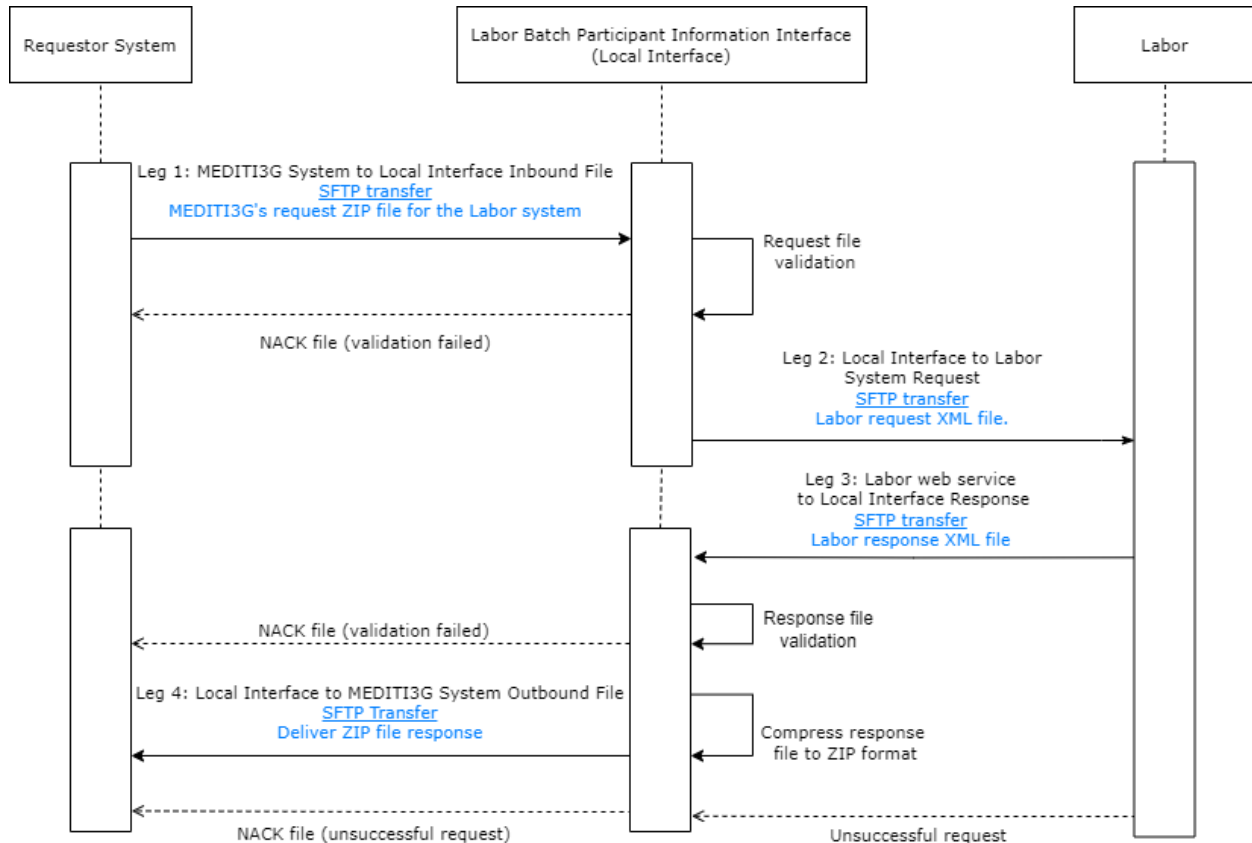

### Leg 1: Requestor System to Local Interface Inbound File

The Labor Batch Participant Information Interface shall receive the transaction. This transaction includes requests with personally identifiable information such as Full Name (First Name, Middle Name if available, and Paternal Last Name), SSN, and DOB.

### Leg 2: Local Interface to Labor System Request.

The interface shall validate manifest metadata and an XML file following NIEM standards containing the request for the Labor System. The interface shall place the validated request received from Requestor System in the Local Interface designated

SFTP directory, where the Labor System shall pick up it. This transaction shall send the requests from Leg 1 to the Labor System.

#### Leg 3: Labor System to Local Interface Response

The interface is responsible for receiving and validating the responses from the Labor system in XML format following NIEM standards. This transaction includes the responses from the Labor System containing personal identifiable information, address, the reported income to the agency and the benefits.

#### Leg 4: Local Interface to Requestor System Outbound File

A manifest file is created for the response file. Both files are compressed in ZIP format. The final ZIP response file is delivered to the Requestor System via SFTP. This transaction shall take the responses from Leg 3 and deliver them to the Requestor System.

### 4.5. Security and Integrity

The State Hub SFTP server allows Labor System to connect through SFTP shared directories, obtain the request file and return the Labor's requested data. The files shall be and decrypted using Pretty Good Privacy (PGP). State Hub shall encrypt the original request file using Labor's PGP public key, so only the agency can decrypt it using their private key and passphrase. Once Labor finishes processing the file and its ready to deliver responses, it shall encrypt the files using the State Hub's PGP public key, so only the State Hub can decrypt them.

## 5. Detailed Interface Requirements

The following section provides a detailed description of the interaction between the Requestor System and the Labor System through the interface in the State Hub.

### 5.1. Requirements for Labor Batch Participant Information Interface

This Labor Batch Participant Information interface shall be used to transfer a match request file from the Requestor System to Labor and back. Full details on this end-to-end process, the requirements that it shall meet, any assumptions that have been made, and constraints that have been identified are outlined in the below sections.



### 5.1.1. Assumptions

The following assumptions are considered for the design of this interface:

The Labor Batch Participant Information Interface shall interact with Labor through the SFTP that resides in the State Hub, as agreed with the agency.

The TDS shall return the batch responses to the Labor Batch Interface SFTP directory.

The Local Agency shall validate the received requests and returned responses.

### 5.1.2. Constraints

The following constraints apply to the interactions between the Requestor System and the Local Interface:

The Local Interface shall only perform matches based on the following combinations:

SSN

First Name and Last Name (paternal)

Date of Birth (DOB)

The Local Agency shall only be available Monday thru Friday from 12:00 am to 10:30 pm and shall only monitor every weekday to check if there is any file pending for processing. If there is no file pending, file processing shall wait for the next business day.

The Requestor System shall send only one batch file per business day.

The Local Agency shall perform searches based on the combination of SSN and DOB, for the Benefits system; and based on the SSN, for the Wages system. Since all fields are needed, the ability to find a result with partially wrong information or miswritten values depends entirely on the matching algorithms of the Local Agency, if any.

### 5.1.3. General Processing Steps

[Table 7 - Labor Batch Participant Information Interface Processing Steps](#) details the processing steps that the interface completes monthly to process the requests from the Requestor System to the Labor System.

*Table 7 - Labor Batch Participant Information Interface Processing Steps*

Processing Step	Description	Responsible
<b>1</b>	<p>The Requestor System is to provide a request file to the State Hub with the LABOR_REQ BatchCategoryCode.</p> <p>The Requestor System deposits the PGP encrypted ZIP file containing the batch requests to its Inbound folder in the State Hub SFTP server.</p>	Requestor System
<b>2</b>	<p>Decrypt the provided ZIP file.</p> <p>Validate the manifest and request files.</p> <p>Send the request file to the Labor Local Interface.</p>	State Hub
<b>3</b>	<ul style="list-style-type: none"> <li>Encrypt the request file using Labor PGP public key.</li> <li>Deposit the file in the Labor service provider Inbound folder in the State Hub SFTP server.</li> </ul>	Local Interface

Table 8 - Labor Batch Participant Information Interface Response Processing details the processing steps that the interface completes to process the response from the ADSEF System to the Requestor System

*Table 8 - Labor Batch Participant Information Interface Response Processing Steps*

Processing Step	Description	Responsible
<b>1</b>	<p>Decrypt the request file.</p> <p>Process the request file.</p> <p>Encrypt the response file with the State Hub PGP public key.</p> <p>Deposit the file in the Labor service provider Outbound folder in the State Hub SFTP server.</p> <p>See Table 9 - Labor Batch Participant Information Interface Response Processing Steps When the Maximum Response Time has Reached for an alternate scenario</p>	Labor
<b>2</b>	<p>Decrypt the response file.</p> <p>Complete the response file adding the missing requested participants with <a href="#">code 0050</a>.</p> <p>Validate the response by participants. If there is an invalid participant, it removes it and substitutes it with code 9999.</p>	Local Interface
<b>3</b>	<ul style="list-style-type: none"> <li>Create a ZIP file with the response and the manifest.</li> <li>Encrypt the ZIP file with the Requestor System PGP public key.</li> <li>Deposit the encrypted file in the Requestor Outbound folder.</li> </ul>	State Hub

**Error! Reference source not found.** details the processing steps that the interface completes when the maximum response time has reached without responses.

*Table 9 - Labor Batch Participant Information Interface Response Processing Steps When the Maximum Response Time has Reached*

Processing Step	Description	Responsible
1	The request file is not retrieved within the maximum response time (9 days), or the response is received after the maximum response time.	Local Agency
2	<ul style="list-style-type: none"> <li>• Create a ZIP file with a timeout NACK response.</li> <li>• Encrypt the ZIP file with the Requestor System PGP public key.</li> <li>• Deposit the encrypted file in the Requestor Outbound folder.</li> </ul>	State Hub

[Table 10 - Labor Batch Participant Information Interface Processing Steps to Delete Inbound File That is 14 Days or Older](#) details the processing steps that the interface completes to delete any file that is fourteen (14) days or older in the Inbound folder.

*Table 10 - Labor Batch Participant Information Interface Processing Steps to Delete Inbound File That is 14 Days or Older*

Processing Step	Description	Responsible
1	The State Hub Storage Account monitors the Inbound folder	State Hub
2	Verify the date that the file was placed in the folder.	State Hub
3	Delete the file if it is fourteen (14) days or older.	State Hub

Table 9 - Labor Batch Participant Information Interface Response Processing Steps details the processing steps that the interface completes to delete any file that is fourteen (14) days or older in the Outbound folder.

*Table 11 - Labor Batch Participant Information Interface Processing Steps to Delete Outbound File That is 14 Days or Older*

Processing Step	Description	Responsible
1	The State Hub Storage Account monitors the Outbound folder.	State Hub
2	Verify the date that the file was placed in the folder.	State Hub
3	Delete the file if it is fourteen (14) days or older.	State Hub

#### 5.1.4. Interface Processing Time Requirements

The minimum and the maximum response time of the batch file shall be within one (1) day. This maximum response time considers that the number of compressed files queued for processing shall be one (1).

Table 12 defines cases where the response time exceeds the stated one (1) calendar day, and consequently the maximum response time.

*Table 12 - Results in cases where the maximum response time is exceeded*

Processing State Scenarios	Result
<b>The Labor Batch Participant Information Interface has not received a response from the Labor System.</b>	The Local Interface shall prepare and return a NACK to the Requestor System.

All the results in these cases shall be audited and presented in audit reports concerning exceeded response time.

### 5.1.5. Message Format (or Record Layout) and Required Protocols

The following section shall detail the format by which the Requestor System shall send participant batch requests to Labor and Labor shall respond to the requests sent by the Requestor System.

#### 5.1.5.1. File Layout

The Labor Batch request and response files are encrypted text files in XML format following NIEM standards. Each batch request file sent by the Requestor System shall follow the file format defined in section 5.1.5.3 Field/Element Definition.

#### 5.1.5.2. Data Assembly Characteristics

The data that is processed in the interface is in XML format following NIEM standards version 2.0. The manifest file shall include detailed information about the batch transaction beings sent to the Labor System. The manifest file contains information such as the number of files sent in the batch, the number of requests being made to Labor, the checksum of the files, and the name of the files within the ZIP file. The maximum file size limit for a Labor request file inside the ZIP file is 104,857,600 bytes (100 megabytes). In terms of individual requests, a single 100 MB request file can hold up to one hundred and twenty-five thousand (125,000) individual requests. The request file can be split up into multiple request files in the case where they exceed this specified file size.

The request file contains one or more individual requests to the Labor System with information about the participant that is going to be located. The request includes a request identifier, the date of birth, and the social security number. On the other hand, the response file created to the Requestor System includes one or more individual responses about the participant and the identifier for each request. Each participant's record returns the personal information stored, address(es), income reported, and benefits reported. See section **Error! Reference source not found.** REF\_Ref25135606 \h \\* MERGEFORMAT **Error! Reference source not found.** for more details.

The NACK file shall inform of any file validation errors encountered in the process and the batch that failed the validation. If any request, attachment, or manifest file in the

ZIP has a validation error, it shall also be specified in the file. The NACK shall also return any error found during schema validation as well as any error captured during the processing of the match request file against the Labor System.

The Labor Batch Participant Information Interface file layouts are defined in section 5.1.5.3: Field/Element Definition.

### 5.1.5.3. Field/Element Definition

The following section details the schema used between the Requestor System and the Local Interface to request participant information from the Local Agency. This section also provides details for errors encountered during the transactions and how the error is reported back to the Requestor System. Section 6 provides a sample schema and sample XML for the data elements in the following section.

#### 5.1.5.3.1. Batch Service Request Manifest Data Elements, NACK Manifest ResponseCodes, and BatchCategoryCodes

The following section shall detail the manifest request schema by which the Requestor System shall send the batch request to the Local Agency, the NACK elements that shall be sent to the Requestor System if any error was encountered while validating the requests, and the error codes that shall be used to inform the Requestor System of the error encountered.

##### 5.1.5.3.1.1. Request Manifest Data Elements

The Requester System that sends batch data verification request to the Local Interface shall populate the request manifest schema to describe the files the Requester is submitting to the State Hub. The name of the request manifest file is manifest.xml.

Figure 6 - High-Level Request Manifest UML illustrates the elements that the manifest request shall contain to submit the requests to the Local Interface. Detailed data elements are described in **Error! Reference source not found.**

*Figure 6 - High-Level Request Manifest UML*

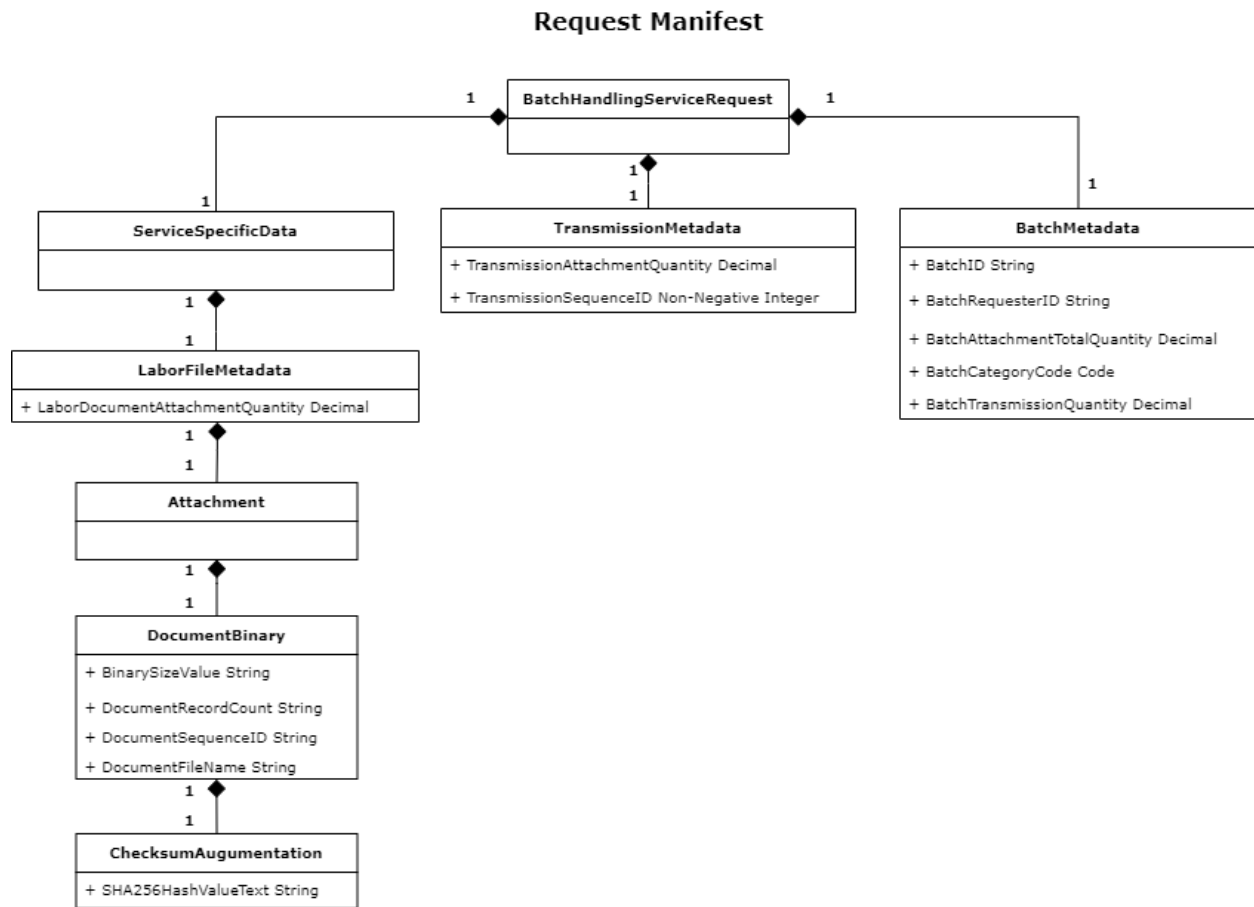

**Error! Reference source not found.** defines the data elements that the request manifest needs for a batch request to be submitted to the Local Interface. The following data elements define the attributes of the TDS-destined file the Requester needs to submit to the State Hub.

*Table 13 - Request Manifest Schema: Requester to State Hub Inbound Batch File*



Microsoft Excel  
Worksheet



5.1.5.3.1.2. *NACK Data Elements*

Table 144 - NACK Manifest Schema: State Hub to Requester NACK file defines the data elements that the State Hub returns to the Requester when an error in validation or during the process was encountered. The detailed information of the errors that are sent in the NACK file is found in section 5.1.5.3.1.3: NACK Manifest ResponseCodes. The following data elements define the attributes of the NACK file that the State Hub returns to the Requester when an error has occurred.

Figure 7 - High Level NACK Manifest UML illustrates the elements that the NACK response shall contain to receive the NACK from the Local Interface. Detailed data elements are described in Table 144 - NACK Manifest Schema: State Hub to Requester NACK file.

*Figure 7 - High Level NACK Manifest UML*

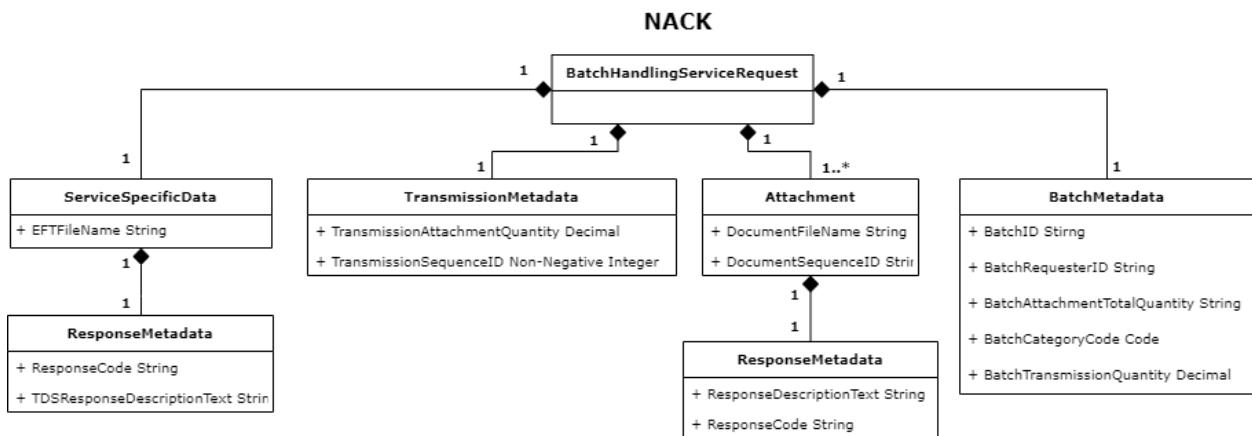

*Table 144 - NACK Manifest Schema: State Hub to Requester NACK file*



Microsoft Excel  
Worksheet

### 5.1.5.3.1.3. NACK Manifest ResponseCodes

Table 15 – NACK Manifest Schema: State Hub to Requester NACK Manifest ResponseCodes defines the NACK Manifest response codes that the State Hub returns to the Requester when an error in validation or during the process where encountered. The following data elements define the attributes of the NACK Manifest ResponseCodes that the State Hub returns to the Requester when an error has occurred.

Table 155 - NACK Manifest Schema: State Hub to Requester NACK Manifest ResponseCodes



Microsoft Excel  
Worksheet

### 5.1.5.3.1.4. NACK Batch Category Codes

Table 16 - NACK Manifest Schema: State Hub to Requester NACK Manifest Category Codes defines the NACK Manifest Category Codes that the State Hub returns to the Requester when an error in validation or during the process where encountered. The following data elements define the attributes of the NACK Manifest Category Codes that the State Hub returns to the Requester when an error has occurred.

Table 16 - NACK Manifest Schema: State Hub to Requester NACK Manifest Category Codes



Microsoft Excel  
Worksheet

### 5.1.5.3.2. Batch Service Response Manifest Data Elements, ResponseCodes, and BatchCategoryCodes

The following section shall detail the manifest response schema by which the Local Interface shall send the response to the Requestor System and the error codes that shall be used to inform the Requestor System of the error encountered.

### 5.1.5.3.2.1. Response Manifest Data Elements

The State Hub populates the response manifest schema to return responses from the TDS to Requesters. The response manifest filename is manifest.xml.

Figure 8 - High Level Response Manifest UML illustrates the elements that the manifest response shall contain to receive the responses from the Local Interface. Detailed data elements are described in Table 17 - Response Manifest Schema: State Hub to Requester File Response.

*Figure 8 - High Level Response Manifest UML*

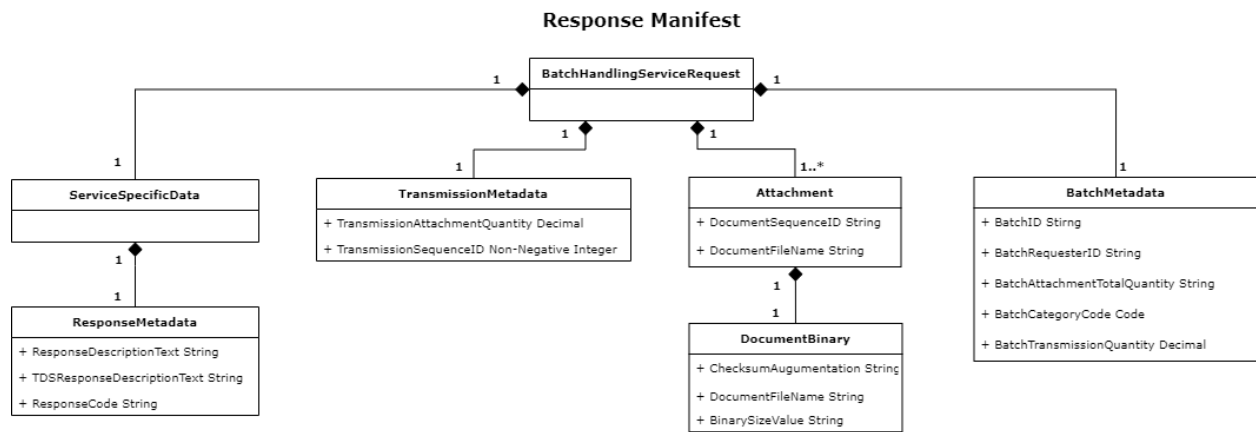

Table 17 - Response Manifest Schema: State Hub to Requester File Response defines the response data elements that the State hub needs to return to the Requester. The following data elements define the attributes of the file that the State hub return to the Requester.

*Table 17 - Response Manifest Schema: State Hub to Requester File Response*



### 5.1.5.3.2.2. Response Manifest File-level ResponseCodes

Table 18 - Response Manifest Schema: State Hub to Requester ResponseCodes defines Manifest File response codes that the State Hub returns to the Requester.



<b>ResponseCode</b>	<b>ResponseDescriptionText</b>	<b>BatchCategoryCode</b>
<b>SHE005009</b>	File Record Count Invalid  Note: This response returns when the record count in the request manifest Schema does not match the actual record count within the Labor file. The Local Interface expects the Requester to correct the condition and resubmit the file with a new BatchID.	LABOR_FILE_REJECTED_RESP
<b>SHE005011</b>	Unexpected Response Code  Note: In these situations, the TDSResponseDescriptionText field describes the condition; the code the State Hub returns appends to the ResponseDescriptionText.	LABOR_FILE_REJECTED_RESP
<b>SHS000000</b>	Success	LABOR_RESP  Note: Record level errors shall exist within the file responses; however, since the TDS data is used to produce a file for the State Hub to return to the Requester, the result is Success.  Note: Labor request and response record counts always match.
<b>SHX005502</b>	Unexpected System Exception  Note: This condition can occur for an Labor file containing null or spaces in required fields. The Team expects the Requester to correct the condition and resubmit the file with a new BatchID.	LABOR_FILE_REJECTED_RESP
<b>SHX005507</b>	File validation error at TDS.	LABOR_FILE_REJECTED_RESP
<b>SHX003001</b>	Unexpected Exception Occurred at Trusted Data Source	LABOR_FILE_REJECTED_RESP

ResponseCode	ResponseDescriptionText	BatchCategoryCode
	Note: This condition can occur for an Labor file containing disallowed XML 1.0 characters or if the file is not prettyprinted (properly formatted) XML 1.0. The Local Interface expects the Requester to correct the condition and resubmit the file with a new BatchID.	

The following data elements define the attributes of the Manifest ResponseCodes that the State Hub returns to the Requester when an error has occurred.

*Table 18 - Response Manifest Schema: State Hub to Requester ResponseCodes*



Microsoft Excel  
Worksheet

#### 5.1.5.3.2.3. Response Manifest BatchCategoryCodes

Table 19 – Response Manifest Schema: State Hub to Requester BatchCategoryCodes defines Manifest File BatchCategoryCodes that the State Hub returns to the Requester. The following data elements define the attributes of the Manifest BatchCategoryCodes that the State Hub returns to the Requester when an error has occurred.

*Table 19 - Response Manifest Schema: State Hub to Requester BatchCategoryCodes*



Microsoft Excel  
Worksheet

### 5.1.5.3.3. Labor File Data Elements and ResponseCode

The following section details the request schema that shall be used to send the requests to the Labor System and the response schema that shall be used to send the responses back to the Requestor System.

#### 5.1.5.3.3.1. Labor Request Data Elements

Figure 9 - High Level Labor Request UML illustrates the elements that the Labor request shall contain to submit the requests to the Local Interface. Detailed data elements are described in [Table 20 - Request Data Elements: Labor Batch Participant Information Interface to Labor Batch System File Request](#).

*Figure 9 - High Level Labor Request UML*

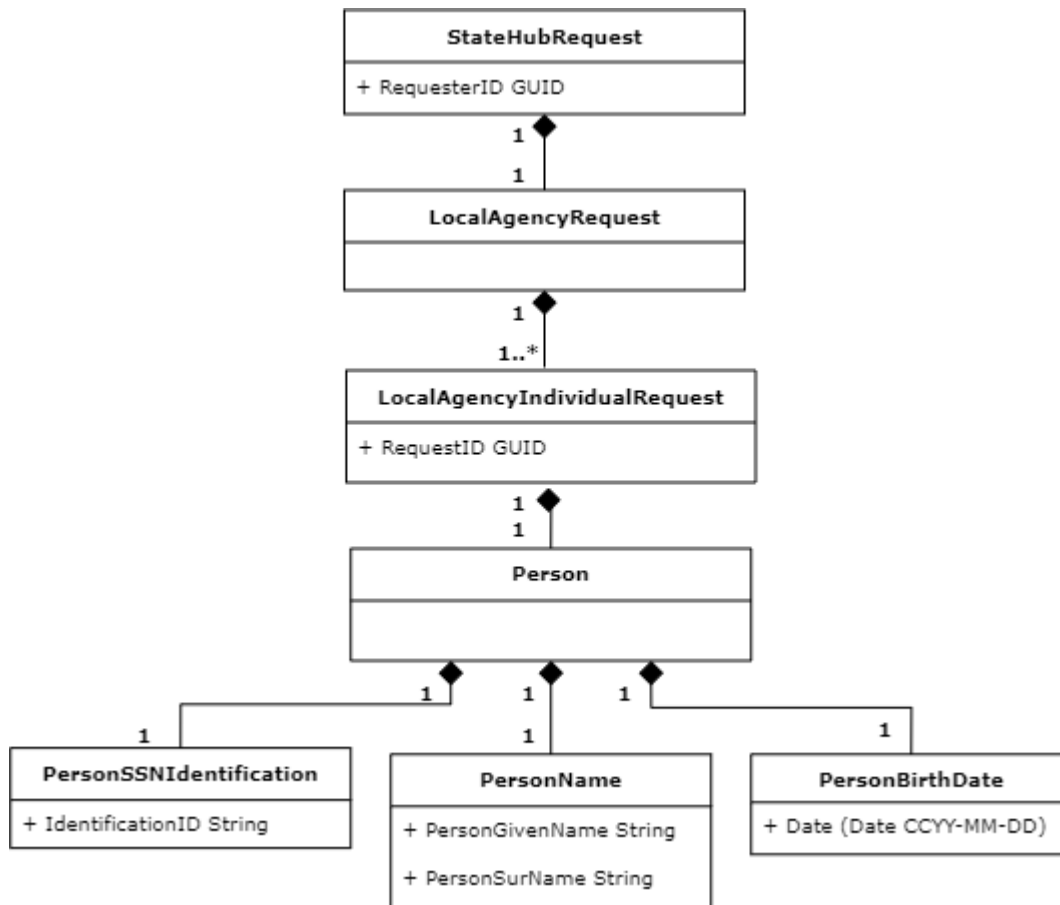

Table 20 - Request Data Elements: Labor Batch Participant Information Interface to Labor Batch System File Request defines the request data elements that the Labor Batch Participant Information Interface needs to be submitted to the Labor Batch

System. The following data elements define the attributes of the TDS-destined file that the Labor Batch Participant Information Interface needs to submit to the Labor System.

*Table 20 - Request Data Elements: Labor Batch Participant Information Interface to Labor Batch System File Request*



#### *5.1.5.3.3.2. Labor Response Data Elements*

Figure 10 - High Level Labor Response UML illustrates the elements that the Labor response shall contain to receive the responses from the Local Interface. Detailed data elements are detailed in Table 21.

*Figure 10 - High Level Labor Response UML*

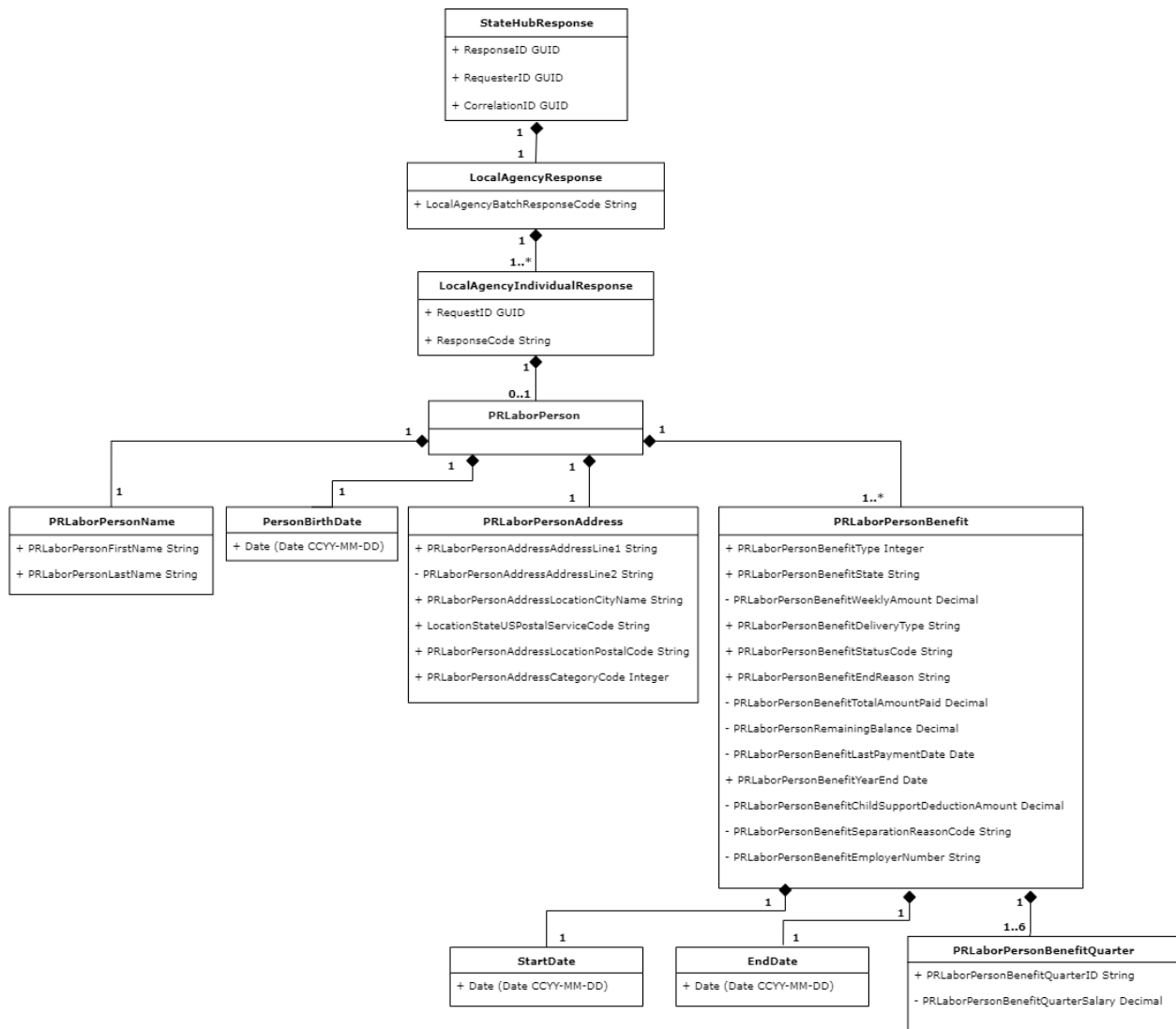

Table 21 - Response Data Elements: Labor Batch Interface to Requestor System File Response defines the Labor Batch Interface response data elements that the Requestor System shall receive.

*Table 21 - Response Data Elements: Labor Batch Interface to Requestor System File Response*



SH-RedMane DOL  
Data Layout with Defa



5.1.5.3.3.3. *Labor ResponseCode*

Table 22 - ResponseCode: Labor Batch Interface LocalAgencyBatchResponseCode defines the LocalAgencyResponseCode that the Labor Batch Interface needs to return to the Requestor System for each segmented batch.

*Table 22 - ResponseCode: Labor Batch Interface LocalAgencyBatchResponseCode*



Table 23 - ResponseCode: Labor Batch Interface LocalAgencyIndividualResponse/ResponseCode defines the LocalAgencyResponseCode that the Labor Batch Interface needs to return to the Requestor System for each segmented batch.

*Table 23 - ResponseCode: Labor Batch Interface LocalAgencyIndividualResponse/ResponseCode*



## 5.1.6. Communication Methods

The following subsections outline the communication requirements for all aspects of the communication stack to which the systems participating in the interface shall conform.

Communication shall be divided into three ways:

- Bi-directionally between the Requestor System and the State Hub
- Within the Local Interface
- Bi-directionally between the Local Interface and TDS.

The Requestor System and the State Hub shall perform connections using an SSH-2 SFTP connection with RSA keys. Inbound connections shall only be able to read and write in a very specific file directory, while outbound connections shall only read files from a different file directory. Packages sent through these connections are limited to request data files, response data files, and NACK XML files. See section 4.3 Data Transfer for detailed information on the folder structure and the composition of the ZIP files.

Within the Local Interface, the components shall communicate with each other using HTTPS requests and responses using REST and exchanging XML. The Local Interface shall also communicate with the SFTP to obtain request files and deposit response files using encryption in compliance with MARS-E.

Labor shall retrieve the request from the State Hub SFTP folder using SSH-2 SFTP connection with RSA keys. The packages being exchanged shall be XML for both the request and the response. Labor System shall use SSH-2 RSA keys to deposit response(s) into the State Hub SFTP folder, the same way as how it establishes connections to the SFTP for retrieving the requests.

For exchange timing requirements see section 5.1.4: Interface Processing Time Requirements.

#### **5.1.6.1. Interface Initiation**

The Local Interface monitors the Inbound Folder by running a mechanism that shall be triggered when a new ZIP file has been deposited in the SFTP, the interface performs different validations to determine if the batch shall continue the workflow on the deposited files.

The connection to the SFTP server is through the SSH-2. The Requestor System shall provide the SFTP server the correct private key to be able to submit the file and initiate the interface execution.

#### **5.1.6.2. Flow Control**

A high-level interaction between the Requestor System-Local Interface-Labor can be seen in Figure 11 - Labor Batch Participant Information Interface Process Flow.

*Figure 11 - Labor Batch Participant Information Interface Process Flow*

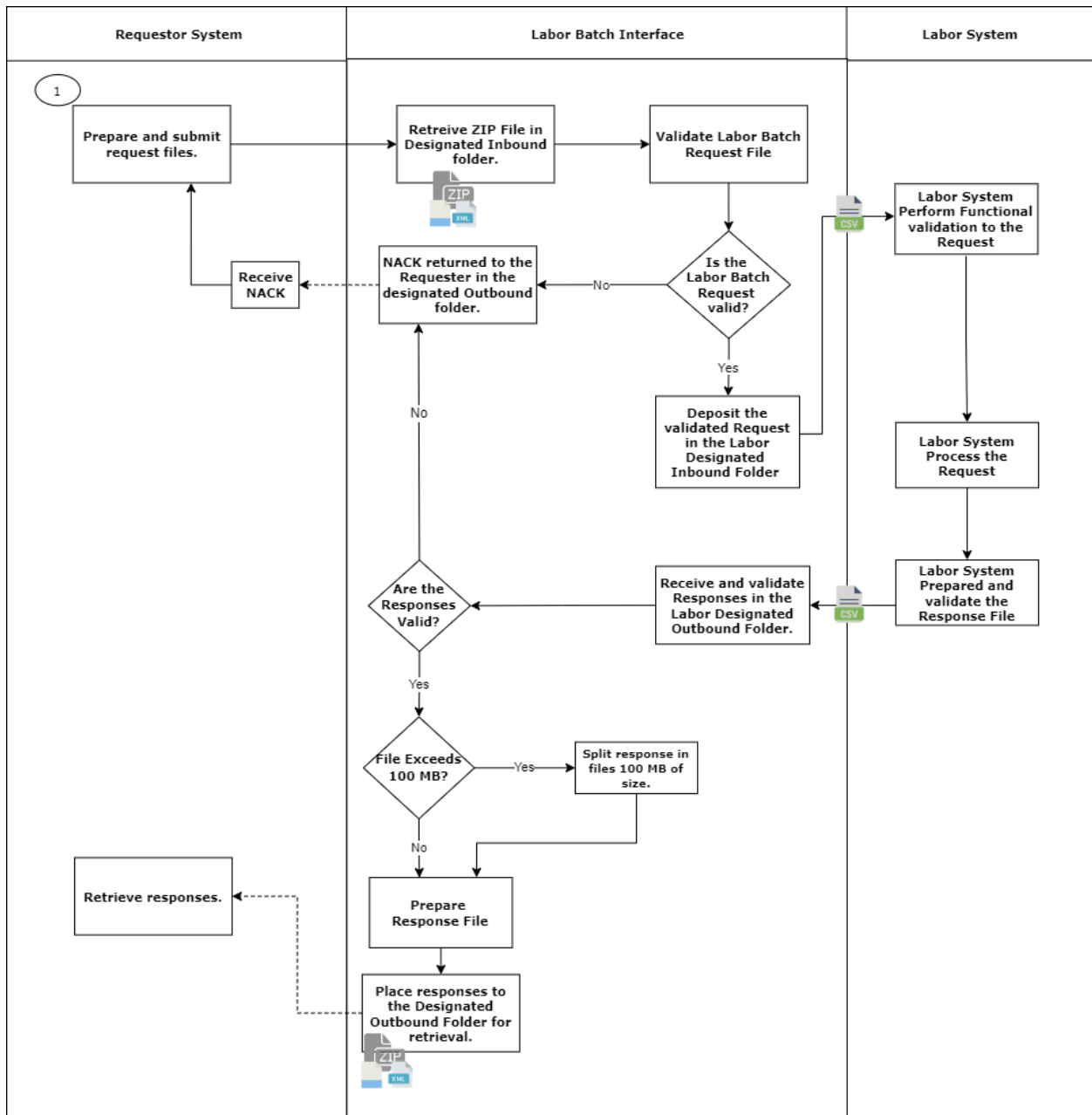

The information regarding the NACK messages sent from the interface to the Requestor System can be found in sections [5.1.5.3.1.3: NACK Manifest ResponseCodes](#), [5.1.5.3.2.1: Response Manifest Data Elements](#), and [5.1.5.3.3.3: Labor ResponseCode](#).

### 5.1.7. Security Requirements

All encryptions shall be done using 256-bit Advanced Encryption Standard (AES). This shall enforce HIPAA, HITECH 2009, FIPS 140-2 requirements as well as MARS-E requirements. Encryption shall be applied to requests, responses, and any data that is processed within the Local Interface and forwarded to Labor or the Requestor System. Operations performed by the Local Interface shall go through a three (3) step process:

1. Decryption
2. Processing
3. Encryption

In other words: for every step of execution within the Local Interface, encryption shall always be managed with these three (3) steps in order to maintain encryption throughout all functionalities.

Data processed by the Local Interface shall also remain encrypted during interface functionality using HTTPS inside the virtual machines and cloud services layer of Azure Government's security model, which is its deepest layer. This data shall never be persisted in any way and shall only be accessible through memory so that it disappears from the State Hub and the Local Interface after any operation performed on it has been completed. Any reference to an operation in our reporting functionality and auditing functionality shall have no direct or indirect mention of the contents of the data that was processed when an alert or audit was performed. References to data values shall never be referenced in logging functionality which shall be limited to data fields or types only when it is necessary to reference them.

The data identified as PII in Section **Error! Reference source not found.:** **Error! Reference source not found.** and **Error! Reference source not found.:****Error! Reference source not found.**, shall only be accessed by the person with the State Hub Administrator role within the State Hub. The State Hub Administrator role possesses the permission to delete but not read a file, this means that if an issue arises, the State Hub Administrator is the person responsible to address the issue.

## 6.XML Schemas

This section provides schemas and examples for the schemas used to communicate by the Requestor System with the Labor System through the Local Interface.

### 6.1. Request and Response Manifest Schemas

Figure 12 - Labor Request and Response Manifest Schema contains the Labor Batch Participant Information manifest XML Schemas for submitting and receiving files. The samples in each ZIP file display examples of manifest schemas. Sections [5.1.5.3.1.1](#) – Request Manifest and [5.1.5.3.2.1](#) – Response Manifest provides detailed information on these schemas.

*Figure 12 - Labor Request and Response Manifest Schema*



**Note:** The sample response manifest Schema is used for NACKS and Responses; therefore, the sample gives a depiction of all populated fields but not a true depiction of an actual scenario. See Section [4.3 - Data Transfer](#) for scenario depictions.

### 6.2. Labor Request and Response Schemas

Figure 13 - Labor Request and Response File Schema contains the XML Schemas that the Requestor System shall use to communicate with the interface and the responses that shall be sent back. Additionally, this schema is used to communicate with the Labor System that the Local Interface interacts with. Section [5.1.5.3.3](#) provides detailed information on the Labor request and response.

*Figure 13 - Labor Request and Response File Schema*



Labor Batch  
Schemas.zip

**Note:** The sample used for the Labor Request and Responses gives a depiction of all populated fields but not a true depiction of an actual scenario.

## 7. Qualification Methods

This Labor Batch Participant Information ICD represents the delivery outcome of the evidence validation and interface analysis that has been gathered. Input from Puerto Rico Medicaid Program Subject Matter Experts and Labor staff was collected during Labor Batch Participant Information Interface JAD sessions and has been considered for this document as well. The qualification methods are aligned to the State Hub qualification methods, to see in detail refer to the Section 5 Release Management in the [State Hub HLD](#).

## 8. Related Documents

This section describes documents that support or are directly related to this document. See [Table 24 - Related Documents](#).

*Table 24 - Related Documents*

Document	Reference
(LABOR)_Requirements and Definitions Document for Local Government Agency	<a href="https://intVOICEpr.sharepoint.com/:w:/r/EnE_P-APDU/Deliverables%20Library/WW_Deliverable%2019-%20Requirements%20and%20Definitions%20Document%20for%20Department%20of%20Labor/Deliverable%2019-%20Requirements%20and%20Definitions%20Document%20for%20Department%20of%20Labor_v1.0.docx?d=w9b056141089d43acbf7a14586decdf4c&amp;csf=1&amp;web=1">https://intVOICEpr.sharepoint.com/:w:/r/EnE_P-APDU/Deliverables%20Library/WW_Deliverable%2019-%20Requirements%20and%20Definitions%20Document%20for%20Department%20of%20Labor/Deliverable%2019-%20Requirements%20and%20Definitions%20Document%20for%20Department%20of%20Labor_v1.0.docx?d=w9b056141089d43acbf7a14586decdf4c&amp;csf=1&amp;web=1</a>
PREE Requirements and Definitions: State Data Verification Hub Requirements	<a href="https://intVOICEpr.sharepoint.com/EnE_P-APDU/layouts/15/Doc.aspx?sourcedoc=%7BF165A982-4031-4AA4-996F-B2423C7BD5A3%7D&amp;file=PREE_StateHub_Requirements_and_Definitions_v1.0.docx&amp;action=default&amp;mobileredirect=true&amp;DefaultItemOpen=1">https://intVOICEpr.sharepoint.com/EnE_P-APDU/layouts/15/Doc.aspx?sourcedoc=%7BF165A982-4031-4AA4-996F-B2423C7BD5A3%7D&amp;file=PREE_StateHub_Requirements_and_Definitions_v1.0.docx&amp;action=default&amp;mobileredirect=true&amp;DefaultItemOpen=1</a>
System Security Plan Document (SSP).	<a href="https://intVOICEpr.sharepoint.com/:f:/r/EnE_P-APDU/PREE_Mediti3G_Audit/Working_folders/Wovenware_Documents?csf=1&amp;web=1&amp;e=jo5u5i">https://intVOICEpr.sharepoint.com/:f:/r/EnE_P-APDU/PREE_Mediti3G_Audit/Working_folders/Wovenware_Documents?csf=1&amp;web=1&amp;e=jo5u5i</a>



Document	Reference
PREE State Hub High Level Document	<a href="https://intvoicepr.sharepoint.com/:f/r/EnE_P-APDU/Deliverables%20Library/WW_Deliverable%20204_HLD%20-%20State%20Data%20Verification%20Hub%20(NEW%20ARCHITECTURE)?d=wbe9e7869017d464aac340ebbd2bf35d7&amp;csf=1&amp;web=1">https://intvoicepr.sharepoint.com/:f/r/EnE_P-APDU/Deliverables%20Library/WW_Deliverable%20204_HLD%20-%20State%20Data%20Verification%20Hub%20(NEW%20ARCHITECTURE)?d=wbe9e7869017d464aac340ebbd2bf35d7&amp;csf=1&amp;web=1</a>



## 9. Requirements Matrix

For requirement traceability purposes, the following requirements are met and mapped to this design document.

*Table 25 - General Functional Requirements*

Item #	ID	Requirement	Fit-Gap	Implementation Details
1.	IR-GR-F-001	The real-time and batch local interfaces shall be hosted in the cloud as services.	Fit	
2.	IR-GR-F-003	The batch local interfaces shall receive batch requests from the MEDITI3G System and route them to their corresponding local agency.	Fit	
3.	IR-GR-F-005	The batch local interfaces shall deliver batch responses from their corresponding local agency to the MEDITI3G System.	Fit	
4.	IR-GR-F-008	The batch local interfaces shall be able to accept one or more batch files for processing.	Fit	
5.	IR-GR-F-009	The batch local interfaces shall send NACKS when a request was not processed due to a validation error, whether NIEM validation error, checksum validation error, or otherwise.	Fit	
6.	IR-GR-F-010	The batch local interface shall return a response if the max agreed upon response time is exceeded. The response shall either be a NACK if whole response file has yet to be processed, or a response batch file with individual responses based on batch processing completed against agency at that time.	Fit	
7.	IR-GR-F-011	The real-time and batch local interfaces shall be uniquely	Fit	



		identifiable from within the State Hub such that audit trails, log files, reporting services and other transactions can be quickly identified per local interface by the administrator user and auditor user when performing administrative tasks from the cloud portal.		
8.	IR-GR-F-012	The real-time and batch local interfaces shall process all PII in transit and shall not retain any PII after the processing is completed.	Fit	
9.	IR-GR-F-013	The batch local interfaces shall allow partial responses for batch transactions.	Fit	
10.	IR-GR-F-015	The real-time and batch local interfaces shall support transporting inbound and outbound data to the MEDITI3G system adhering to the NIEM standard.	Fit	
11.	IR-GR-F-016	The real-time and batch local interfaces shall send PII as search criteria to locate the person/participant at the local agency.	Fit	
12.	IR-GR-F-017	The real-time and batch local interfaces shall receive a response from their respective local agency with the participant information pre-defined data elements.	Fit	
13.	IR-GR-F-018	The batch local interface shall allow MEDITI3G System to submit a batch request file for querying the local agency System for Participant(s) Information, to be returned within one or more response files.	Fit	
14.	IR-GR-F-020	The batch local interface request file shall contain a batch set of individual participant requests, each request containing participants PII search criteria.	Fit	

15.	IR-GR-F-021	The real-time and batch local interfaces shall validate request files submitted by MEDITI 3G System for message format compliance and integrity.	Fit	
16.	IR-GR-F-022	The real-time and batch local interfaces shall support the ability to retry a transaction, without manual intervention, after the Local Agency becomes unavailable mid-transaction.		
17.	IR-GR-F-023	The real-time and batch local interfaces shall capture a metric of whether the Local Agency endpoint is online or unavailable at the time of its use, including any retry attempts and their outcomes.	Fit	
18.	IR-GR-F-024	In case of connectivity issues between the batch local interface and the Local Agency, the batch Local Interface shall retry establishing connection and processing the transaction every half-hour (30 minutes) for up to the max response time or a consecutive 24-hour window of not communicating. Each attempt of reconnecting shall be notified to the State Hub.	Fit	
19.	IR-AR-F-002	<p>The batch local interfaces shall log events resulting from requests received from the MEDITI3G System through the State Hub and the response from their corresponding local agency. At a minimum, events that shall be logged are:</p> <p style="padding-left: 40px;">Batch file received for batch transactions.            Size of the batch ZIP file in KB, MB, or GB            Size of the batch file's XML document in KB, MB, or GB            File validation results.            Requester ID captured            Request transformation results (optional).</p>	Fit	



		<p>Result of connectivity attempt to the local agency.            Connection was established to the local agency (timestamp).            Connection timeout between interface and local agency.            Agency query results            Error code            Response transformation results (optional)            Transaction completed after transmitting data to the local agency.            Correlation ID captured.            File placed for pick-up.            File picked-up.</p> <p>File auto-removed.</p>		
20.	IR-AR-F-003	The real-time and batch local interfaces shall log error codes accompanied by an unvarying, standard description that defines what the error code means when an exception occurs.	Gap	Further details will be provided in the Design Document.
21.	IR-AR-F-004	The real-time and batch local interfaces shall relay audit trails related to warnings and errors to the State Hub using a normalized coding structure so that they are easily identifiable for auditing and troubleshooting purposes.	Gap	Further details will be provided in the Design Document.
22.	IR-AR-F-005	The real-time and batch local interfaces shall not store PII in audit trails.	Fit	
23.	IR-AR-F-006	The real-time and batch local interfaces shall capture non-personal identifying invalid data in the communication (request and response) to help with troubleshooting.	Fit	
24.	IR-SR-F-001	The real-time and batch local interfaces shall ensure that if a failure occurs, no sensitive information, such as PII is vulnerable to external attacks	Fit	



		via interface responses or captured audit trail.		
25.	IR-SR-F-002	The real-time and batch local interfaces shall keep data encrypted during transit as originated from the MEDITI3G System and the Local Agency.	Fit	
26.	IR-SR-F-003	The real-time and batch local interfaces shall establish a secure connection with the MEDITI3G System and the Local Agency.	Fit	
27.	IR-SR-F-004	The batch local interfaces shall keep data encrypted at rest while the transaction is being processed.	Fit	
28.	IR-SR-F-005	The batch local interfaces shall permanently remove all batch files, after the request has been processed and the response has been sent to the MEDITI3G System.	Fit	
29.	IR-SR-F-006	The real-time and batch local interfaces shall comply with the security guidelines and recommendations established in the Patient Protection and Affordable Care Act of 2010, Section 1561.	Fit	
30.	IR-SR-F-007	The real-time and batch local interfaces shall comply with the security requirements established by the HITECH 2009.	Fit	
31.	IR-SR-F-008	The real-time and batch local interfaces shall restrict access to appropriately authenticated systems (for example, MEDITI3G System and Local Agencies' Systems).	Fit	
32.	IR-SR-F-009	The real-time and batch local interfaces shall restrict access to appropriately authenticated users (for example, administrator and auditor).	Fit	
33.	IR-SR-F-010	The real-time and batch local interfaces shall allow an administrator, without granting read	Fit	

		access, to delete an in-transit file (stuck in-transit).		
34.	IR-SR-F-011	The batch local interfaces shall securely purge (delete) any file that reaches or surpasses the predefined time for processing.	Fit	
35.	IR-GR-F-LB-001	The Labor real-time and batch local interfaces shall support the ability to retry a transaction, without manual intervention, after the local agency becomes unavailable mid-transaction.	Both	The interfaces shall stop retrying after a predetermined amount of retries have been performed or some predefined time elapsed (timeout).
36.	IR-GR-F-LB-002	The Labor real-time and batch local interfaces shall capture metric of whether the local agency endpoint is online or unavailable at the time of its use, up to including any retry attempts.	Both	

*Table 266 - General Non-Functional Requirements*

Item #	ID	Requirement	Fit-Gap	Implementation Details
	IR-GR-NF-004	The batch local interfaces shall process batch uncompressed XML files that do not exceed one hundred (100) Megabytes (MB).	Fit	
	IR-GR-NF-005	The batch local interfaces shall be able to process up to five (5) concurrent batch request files.	Fit	
	IR-GR-NF-006	The batch local interface shall expose an SFTP directory so that MEDITI3G System may submit batch requests files for batch querying.	Fit	
	IR-GR-NF-007	The batch local interface shall expose an SFTP directory so that MEDITI3G System may pick up any batch	Fit	



		response files destined for MEDITI3G System.		
	IR-GR-NF-008	The batch local interfaces shall permanently remove in-transit files that has not been used within fourteen (14) calendar days.	Fit	
	IR-GR-NF-009	The real-time and batch local interfaces shall comply with HIPAA and MARS-E regulations to guarantee data encryption, protection, portability, and integrity.	Fit	
	IR-GR-NF-012	The batch interfaces shall support Application-to-Application asynchronous behavior for batch requests.	Fit	
	IR-GR-NF-013	In case of connectivity issues between the batch local interfaces and the Local Agency, the Local Interface shall retry establishing connection and processing the transaction every half-hour (30 minutes) for up to the max response time or a consecutive 24-hour window of not communicating. Each attempt of reconnecting shall be notified to the State Hub.	Fit	
	IR-LR-NF-001	The real-time and batch local interfaces shall generate alerts and notifications through the State Hub using monitoring capabilities.	Gap	Further details shall be provided in the Design Document.
	IR-MR-NF-001	The real-time and batch local interfaces shall capture metrics on the availability of the service provider (local agency). The metric shall compliment the State Hub's service provide monitoring capabilities.	Gap	Further details shall be provided in the Design Document.
	IR-SR-NF-001	The real-time and batch local interfaces that support Secure Socket Layer (SSL) connections shall be supported by public key/private key encryption SSL certificates with 256-bit encryption or stronger.	Fit	

IR-SR-NF-002	The security configurations and conditions that the real-time and batch local interfaces are required to implement in a production environment shall be the same configurations and conditions implemented in all development, testing, integration, and acceptance test environments to guarantee compliance with the security measures in the MARS-E for protecting PII.	Fit	
IR-SR-NF-003	The real-time and batch local interfaces development and development tests shall not use real data for development or testing environments.	Fit	
IR-SR-NF-004	The batch local interfaces shall perform source to destination file integrity checks for exchange of data to ensure no corrupted data reaches to or is extracted from the local agency.	Fit	
IR-GR-NF-LB-001	The real-time and batch local interfaces shall receive and process a response from Department of Labor.	Both	Some data elements may not be provided due to them not being captured by the agency.
IR-GR-NF-LB-002	The Department of Labor shall extract the request file for batch processing from the agency's pre-assigned SFTP endpoint within the local agency.	Batch	
IR-GR-NF-LB-003	The Department of Labor shall deposit the response file for batch requests into the agency's pre-assigned SFTP endpoint within the State Hub.	Batch	
IR-GR-NF-LB-004	The Puerto Rico Department of Labor batch local interface shall have a maximum response time of one (1) day.		



## 10. Issue Register

This section shall capture the identified issues that caused a change to the Local Interface.

*Table 277 - Issue Register*

Issue #	Issue	Resolution	Resolution Date
None identified at this moment			

## 11. Appendix A – Labor Connectivity and Maintenance Plan

The following section provides a summary of the plan that Wovenware has been able to arrange with Labor for this Local Interface:

There shall be a signed Memorandum of Understanding (MOU) agreement in place with Labor to allow the sharing of Labor System information.

The Local Agency shall have maintenance windows at least one or two times a month during the weekends.

The Local Agency shall locate the participant based on the combination given of SSN and DoB, for the Benefits system; and using the SSN only, for the Wages system.

The Local Agency shall be available Monday thru Friday from 8:00 pm to 10:00 pm and shall monitor every weekday to check if there is any file pending for processing.

Once the Local Agency receive the request they shall process and return the response within 24 hours.

The Local Agency shall promptly notify PRDoH of any maintenance window not previously scheduled or agreed upon.

The Labor Batch Participant Information Interface shall interact with Labor through an SFTP that resides in the State Hub, as agreed with the agency.

The Local Agency shall return the batch responses to the Labor Batch Interface SFTP directory.

The Local Agency shall validate the received requests and returned responses.

## 12. Appendix B – Labor Batch Data Layout

**Error! Reference source not found.** Layout show examples of response data fields.

**Note:** This document was created and written by the Labor agency.

*Figure 14 - Labor Batch Data Layout*



MEDICAID Record  
Layout.xlsx

## 13. Appendix C - LocationStateUSPostalServiceCode Accepted Values

The following table lists all the possible US Postal Service Codes that a participant shall have.

*Table 288 - US Postal Service Codes*

LocationStateUSPostalServiceCode Accepted Values	Description
<b>AA</b>	Armed Forces Americas (except Canada)
<b>AE</b>	Armed Forces Europe, the Middle East, and Canada
<b>AK</b>	ALASKA
<b>AP</b>	Armed Forces Pacific
<b>AR</b>	ARKANSAS
<b>AS</b>	AMERICAN SAMOA
<b>AZ</b>	ARIZONA
<b>CA</b>	CALIFORNIA
<b>CO</b>	COLORADO
<b>CT</b>	CONNECTICUT
<b>DC</b>	DISTRICT OF COLUMBIA
<b>DE</b>	DELAWARE
<b>FL</b>	FLORIDA
<b>FM</b>	FEDERATED STATES OF MICRONESIA



<b>LocationStateUSPostalServiceCode Accepted Values</b>	<b>Description</b>
<b>GA</b>	GEORGIA
<b>GU</b>	GUAM GU
<b>HI</b>	HAWAII
<b>IA</b>	IOWA
<b>ID</b>	IDAHO
<b>IL</b>	ILLINOIS
<b>IN</b>	INDIANA
<b>KS</b>	KANSAS
<b>KY</b>	KENTUCKY
<b>LA</b>	LOUISIANA
<b>MA</b>	MASSACHUSETTS
<b>MD</b>	MARYLAND
<b>ME</b>	MAINE
<b>MH</b>	MARSHALL ISLANDS
<b>MI</b>	MICHIGAN
<b>MN</b>	MINNESOTA
<b>MO</b>	MISSOURI
<b>MP</b>	NORTHERN MARIANA ISLANDS
<b>MS</b>	MISSISSIPPI
<b>MT</b>	MONTANA



<b>LocationStateUSPostalServiceCode Accepted Values</b>	<b>Description</b>
<b>NC</b>	NORTH CAROLINA
<b>ND</b>	NORTH DAKOTA
<b>NE</b>	NEBRASKA
<b>NH</b>	NEW HAMPSHIRE
<b>NJ</b>	NEW JERSEY
<b>NM</b>	NEW MEXICO
<b>NV</b>	NEVADA
<b>NY</b>	NEW YORK
<b>OH</b>	OHIO
<b>OK</b>	OKLAHOMA
<b>OR</b>	OREGON
<b>PA</b>	PENNSYLVANIA
<b>PR</b>	PUERTO RICO
<b>PW</b>	PALAU
<b>RI</b>	RHODE ISLAND
<b>SC</b>	SOUTH CAROLINA
<b>SD</b>	SOUTH DAKOTA
<b>TN</b>	TENNESSEE
<b>TX</b>	TEXAS
<b>UT</b>	UTAH



LocationStateUSPostalServiceCode Accepted Values	Description
<b>VA</b>	VIRGINIA
<b>VI</b>	VIRGIN ISLANDS
<b>VT</b>	VERMONT
<b>WA</b>	WASHINGTON
<b>WI</b>	WISCONSIN
<b>WV</b>	WEST VIRGINIA
<b>WY</b>	WYOMING

## 14. Appendix D - PRLaborPersonAddressCategoryCode Accepted Values

The following table lists all the possible PR Labor Person Address Category Codes that a participant shall have.

*Table 299 – PR Labor Person Address Category Codes*

PRLaborAddressCategoryCode Accepted Values	Description
<b>01</b>	Physical
<b>02</b>	Postal
<b>03</b>	Other

## 15. Appendix E - PRLaborPersonBenefitType Accepted Values

The following table lists all the possible PR Labor Person Benefit Types that a participant shall have.

*Table 30 – PR Labor Person Benefit Type Codes*

PRLaborBenefitType Accepted Values	Description
<b>00</b>	UI – Unemployment Insurance
<b>01</b>	EB – Extended Benefits
<b>02</b>	PAB – Program Adding Benefits
<b>03</b>	FSC – Federal Supplemental Compensation
<b>04</b>	DUA – Disaster Unemployment Assistance

PRLaborBenefitType Accepted Values	Description
<b>05</b>	PABA - Program Adding Benefits for Agriculture
<b>06</b>	TRA – Trade Readjustment Allowances
<b>07</b>	TC – PEUC – Temporary Compensation – Pandemic Emergency Unemployment Compensation

## 16. Appendix F - PRLaborPersonBenefitDeliveryType Accepted Values

The following table lists all the possible Labor Delivery Type codes that a participant shall have.

*Table 31 - Labor Benefit Frequency Codes*

PRLaborPersonBenefitDeliveryType Accepted Values	Description
<b>CK</b>	Check
<b>DD</b>	Direct Deposit
<b>Other</b>	Another delivery type



## 17. Appendix G - PRLaborBenefitEndReason Accepted Values

The following table lists all the possible Labor Benefit End Reason codes that a participant shall have.

*Table 32 - Labor Benefit End Reason Codes*

PRLaborBenefitEndReason Accepted Values	Description
<b>00</b>	Normal
<b>01</b>	ABT Expired
<b>02</b>	Use up benefit
<b>03</b>	Inactivity, payment = 0, more than 4 weeks without claiming from his ABE
<b>04</b>	Stopped claiming, payment > 0 and more than 4 weeks without claiming

## 18. Appendix H – PRLaborPersonBenefitStatusCode Accepted Values

The following table lists all the possible Labor Benefit Status Codes that a participant shall have.

*Table 33 - Labor Person Benefit Status Codes*

PRLaborPersonBenefitStatusCode Accepted Values	Description
<b>01</b>	REGULAR-ACTIVE

<b>PRLaborPersonBenefitStatusCode Accepted Values</b>	<b>Description</b>
<b>02</b>	REGULAR-INACTIVE
<b>09</b>	MONETARILY-INELIG
<b>10</b>	BENEFITS-EXHAUSTED
<b>11</b>	TOTAL-DISQUAL-BYE
<b>12</b>	WITHDRAWN
<b>13</b>	DECEASED-ACTIVE
<b>14</b>	CONVERTED
<b>15</b>	CONVERTED-NO-PAY

## 19. Appendix I – **PRLaborPersonBenefitSeparationReasonCode Values**

The following table lists all the possible Labor Person Benefit Separation Reason Codes that a participant shall have.

*Table 344 - Labor Person Benefit Separation Reason Codes*

<b>PRLaborDismissalReasonCode Accepted Values</b>	<b>Description</b>
<b>09</b>	Job shortage
<b>10</b>	Resignation
<b>20</b>	Dismissal
<b>30</b>	Another reason

<b>PRLaborDismissalReasonCode Accepted Values</b>	<b>Description</b>
<b>09</b>	Termination of contract
<b>09</b>	Temporary closure
<b>09</b>	Staff reduction
<b>09</b>	Economy
<b>09</b>	Company Restructuring
<b>13</b>	Resignation gender violence
<b>14</b>	Resignation sick relative
<b>15</b>	Resignation couple relocation
<b>16</b>	Resignation crime victim
<b>23</b>	Dismissal gender violence
<b>24</b>	Dismissal sick relative
<b>25</b>	Dismissal couple relocation
<b>26</b>	Dismissal crime victim
<b>32</b>	Disaster
<b>33</b>	Pandemic-Virus

## 21. Appendix K – Default Values Mapping

The following table lists the default values that the Labor System response shall map to the State Hub Response.

*Figure 15 - Labor System Response Default Values Mapping*



Labor Data Default  
Values.xlsx